

Series 815 ASME Class 150 and series 830 ASME Class 300 Jamesbury™ Wafer-Sphere™ high performance butterfly valves

Jamesbury™ Wafer-Sphere high-performance butterfly valves provide long-lasting tight shutoff capability, excellent flow characteristics, and long service life. The following standard sizes are available:

815W (Class 150 Wafer-Body Design)	2-1/2"–30" (DN 65–750)
815L (Class 150 Single-Flange Design)	2-1/2"–60" (DN 65–1500)
F815 (Class 150 Fire-Tested Version)	3"–60" (DN 80–1500)
818W (CE Marked Class 150 Wafer-Body Design)	2-1/2"–30" (DN 65–750)
818L (CE Marked Class 150 Single Flange Design)	2-1/2"–30" (DN 65–750)
F818 (CE Marked Class 150 Fire-Tested Version)	3"–30" (DN 80–750)
830W (Class 300 Wafer-Body Design)	3"–30" (DN 80–750)
830L (Class 300 Single-Flange Design)	2-1/2"–36" (DN 65–900)
F830 (Class 300 Fire-Tested Version)	3"–36" (DN 80–900)
838W (CE Marked Class 300 Wafer-Body Design)	3"–24" (DN 80–600)
838L (CE Marked Class 300 Single Flange Design)	2-1/2"–24" (DN 65–600)
F838 (CE Marked Class 300 Fire-Tested Version)	3"–24" (DN 80–600)

The Wafer-Sphere high-performance butterfly valve is available in a range of materials and seat combinations suitable for service in a wide variety of applications including NACE MR0103, and abrasive services. Also available are valves specifically prepared for chlorine, oxygen and high-vacuum applications.

Features

Field-proven single-piece flexible seat design

- Xtreme™ seat provides longer life, expanded performance boundaries, and greater value
- Lip-seal design compensates for temperature and pressure changes
- No additional o-rings or metal parts required to maintain tightness
- Tight shut-off in either direction
- Longer service life with less maintenance

Offset shaft and eccentric disc

- No seat/disc contact in the open or intermediate position
- Eliminates wear points at top and bottom of seats for higher cycle life
- Reduces torque requirements, allowing for smaller operators

Fire-tested version available

- Fire-Tite™ Wafer-Sphere valves have been tested to API 607 and ISO-10497-5:2004

CE marked versions available

- CE marked and documented valves that conform to the European Pressure Equipment Directive (PED) 2014/68/EU are available in ASME Class 150/300, both standard and Fire-Tite construction. Operating torques, construction options and valve dimensions are exactly the same as the standard ASME 150/300 offering. The applicable sizes for CE marked valves are shown in table to left.



Positive shaft retention

- 2-1/2" - 24" (DN 65 - 600) valves are equipped with a retaining ring at the top of the shaft to prevent movement of the top portion of the shaft past the compression ring if for any reason the shaft should break within the valve.

Easy seat maintenance

- Simply remove body insert and replace seat – disassembly of disc and shaft is not required

Excellent for both on-off and control applications

- Superior control characteristics
- Inherent flow characteristic is modified equal percentage
- Wide rangeability
- Tight shut-off even in control applications
- Standard lugged style valves are suitable for bidirectional dead-end service at the full pressure/temperature rating of the valve.

Single-source responsibility

- Purchase valves, actuators and accessories, completely mounted from one source
- Available with electric, manual gear and pneumatic double acting or spring return actuators and a variety of accessories including limit switches, solenoids and positioners
- OEM service available through world-wide service centers

Available in a wide choice of materials for a broad range of applications

- Standard body materials include carbon steel, stainless steel, Alloy 20 and Monel®. Other materials, such as Avesta® 254SMO are available on application.

Additional information

Please refer to the bulletins listed below for additional information on other Jamesbury high-performance butterfly valves.

Wafer-Sphere polymer (soft) seat HP Butterfly valves

Cryogenic Service	W130-1
Steam Service	W150-1
Chlorine Service	W150-2
Oxygen Service	W150-3
Vacuum Service	W150-4
Jacketed Valves	W151-3

Specifications

Valve seat ratings

Seat ratings, shown by the graph at right, are based on differential pressure with the *disc in the fully closed position* and refer to **seats** only. Maximum body working pressures are shown in the **Valve Body Ratings** tables below.

Valve body ratings

The tables below are maximum working pressure ratings of the **valve body only**. The seat ratings determine the practical pressure limitations according to actual service conditions. Test pressures are for hydrostatic test with disc open.

Series 815, Class 150 Valve body ratings – psi				
Temp °F	Carbon steel*	316 Stainless steel*	Alloy 20*	Monel
-20 to 100	285	275	230	230
200	260	235	200	200
300	230	215	180	190
400	200	195	160	185
500	170	170	150	170
Test pressure	450	425	350	350

Series 815, Class 150 Valve body ratings – bar				
Temp °C	Carbon steel*	316 Stainless steel*	Alloy 20*	Monel
-29 to 38	19.6	19.0	15.9	15.9
100	17.7	16.2	13.5	13.7
150	15.8	14.8	12.3	13.1
200	13.8	13.7	11.3	12.8
250	12.1	12.1	10.4	11.9
Test pressure	30	29	24	24

Series 830, Class 300 Valve body ratings – psi				
Temp °F	Carbon steel*	316 Stainless steel*	Alloy 20*	Monel
-20 to 100	740	720	600	600
200	680	620	520	530
300	655	560	465	495
400	635	515	420	480
500	605	480	390	475
Test pressure	1125	1100	900	900

Series 830, Class 300 Valve body ratings – bar				
Temp °C	Carbon steel*	316 Stainless steel*	Alloy 20*	Monel
-29 to 38	51.1	49.6	41.4	41.3
100	46.6	42.2	35.3	36.2
150	45.1	38.5	32.0	34.1
200	43.8	35.7	29.4	33.1
250	41.9	33.4	27.2	32.8
Test pressure	77	75	63	63

* Ratings correspond to ASME B16.34 for material grades shown in bills of material herein.

Seat ratings

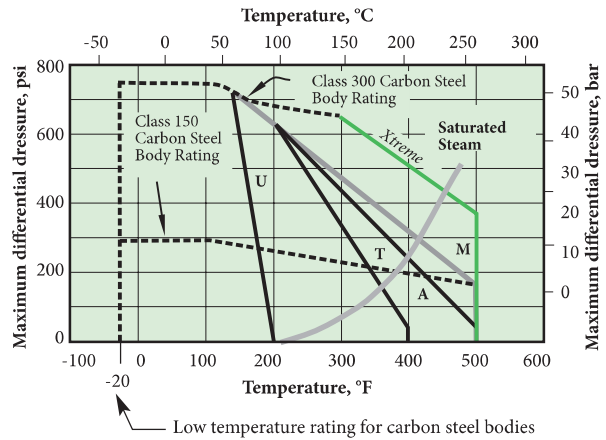

X – Xtreme T – PTFE M – Filled PTFE Seat
A – Fire-Tite U – UHMW Polyethylene

NOTE: 14” – 60” (DN 350 – 1500) Class 150 valves equipped with 316 stainless, Alloy 20 or Hastelloy® C shafts are rated for maximum differential pressure of 150 psi (10.35 bar). 3” – 36” (DN 80 – 900) Class 300 valves equipped with 316 stainless, Alloy 20 or Hastelloy C shaft are rated for maximum differential pressure of 300 psi (20.7 bar). These ratings are a conservative guide for general service. Previous experience in a process or new developments and alternative seat materials may permit applications at ratings above those shown. Please consult our home office for specific recommendations.

Flow data

The tables below provide flow coefficients for Series 815 and 830 butterfly valves covered in this bulletin. The C_v values represent the number of gallons per minute of +60°F water that flows through a fully open valve at a pressure drop of 1 psi. The metric equivalent, K_v , is the flow of water at 16°C through the valve in cubic meters per hour at a pressure drop of 1kg/cm². To convert C_v to K_v , multiply by 0.8569. C_v values for partially open valves are given below.

Series 815		
Valve size		C_v
Inches	DN	
2-1/2	65	78
3	80	165
4	100	400
5	125	650
6	150	1,050
8	200	2,200
10	250	3,300
12	300	5,100
14	350	5,800
16	400	8,000
18	450	10,500
20	500	14,000
24	600	21,600
30	750	34,000
36	900	55,500
42	1050	82,650
48	1200	108,300
54	1350	133,500
60	1500	159,000

Series 830		
Valve size		C_v
Inches	DN	
2-1/2	65	78
3	80	165
4	100	400
5	125	650
6	150	1,050
8	200	1,800
10	250	3,150
12	300	4,750
14	350	5,200
16	400	6,900
18	450	9,300
20	500	11,300
24	600	18,500
30	750	29,100
36	900	47,500

Flow data (continued)

To determine C_v values for a valve in an intermediate position:
 (1) determine the percent of maximum C_v from the graph at right
 (2) multiply the percent of maximum C_v shown on the graph by the C_v value from the appropriate **Flow Data** table on the previous page.

EXAMPLE: The C_v for a 6" (DN 150) 815 that is 70% open is:

- (1) From the graph, a 6" (DN 150) 815 that is 70% open has a C_v value that is 53% of the maximum C_v .
- (2) 53% of the maximum $C_v = 0.53 \times 1050 = 560$.

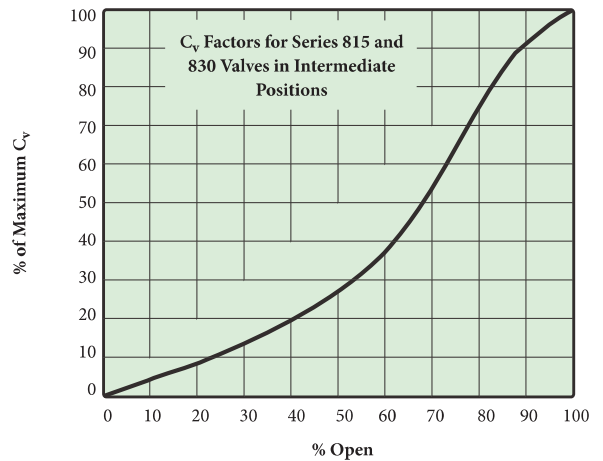

Seat tightness

ANSI/FCI 70-2 establishes a series of six leakage classes for control valves and defines the test procedure. Class VI allows the least leakage. Wafer-Sphere High Performance Butterfly Valves are bubble-tight, MSS-SP61, which would exceed Class VI requirements.

Seat designs

Xtreme performance and value

Xtreme seats provide longer life, expanded performance boundaries, and the greatest possible value. Xtreme is a

unique material that resulted from a technological breakthrough in our polymer research lab. The material is a fluoropolymer-based blend proprietary to Jamesbury that provides superior quarter-turn performance.

Standard seats

Wafer-Sphere standard seat design, constructed of PTFE, Filled PTFE, or UHMW Polyethylene, utilizes a flexible lip, which, when distorted, will always attempt to return to its original shape and maintain a seal against the disc regardless of flow direction.

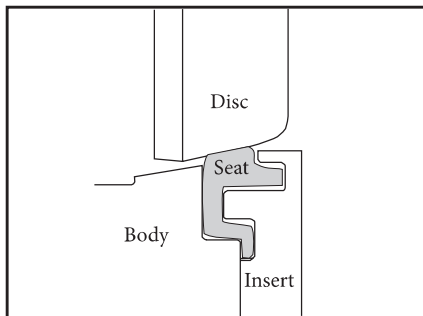

When the valve is shut, the disc slightly deflects the seat. This slight deflection "energizes" the seat. While energized, the sealing surface of the seat is constantly pushing against the edge of the disc.

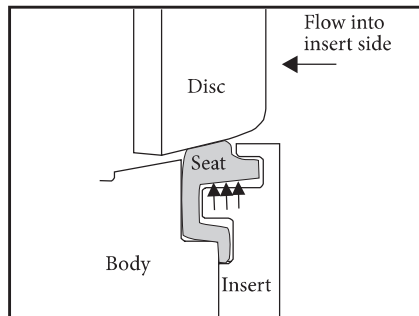

When pressure is on the insert side, pressure is applied under the seat lip. This further amplifies the sealing force between the disc and the seat.

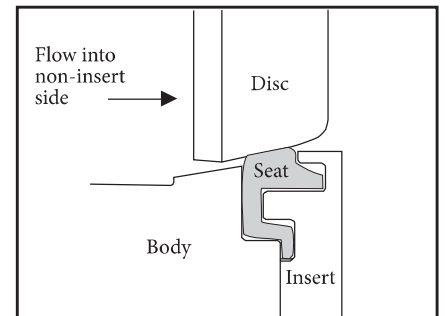

When pressure is on the non-insert side, the disc moves into the seat. Due to the spherical profile of the disc, the more the disc moves into the seat, the tighter the shut-off. Excessive movement of the seat is limited by the flexible lip which contacts the bottom of the groove in the insert ring.

Fire-Tite seats

The Fire-Tite seat was developed for applications where effective shut-off during a fire is a concern. The primary sealing element is Xtreme with a back-up metal seat ring. In the event that the Xtreme is destroyed, the secondary metal seat provides effective shut-off. The Fire-Tite seat is also ideal for critical or severe service applications. Wafer-Sphere butterfly valves with Fire-Tite seats have been tested and approved to API 607 and to ISO-10497-5.

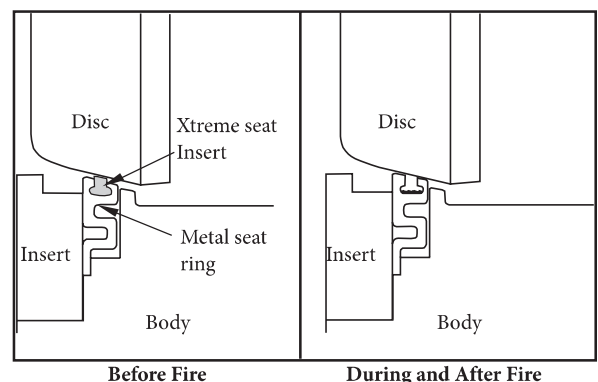

Special services

Emission-Pak™ live-loaded packing

When enhanced emissions control is needed to comply with evolving emissions standards, Emission-Pak live-loaded packing is available. The Emission-Pak live-loaded packing assembly includes PTFE V-ring packing live-loaded with disc spring washers for standard construction valves and graphite packing with Inconel disc springs for Fire-Tite valves to maintain a constant packing force without overcompression. It is available with new valves or as a retrofit kit for existing valves.

Additional options, available with or without the Emission-Pak live-loaded packing, include double packing or double packing with monitoring port to facilitate testing of the primary seal and allow detection of a potential leak problem. Refer to the How to Order section at the end of this bulletin for specific ordering instructions. The **operating torque** of valves with Emission-Pak live-loaded packing will increase. (Refer to the torque equation in the Valve Torque Data section).

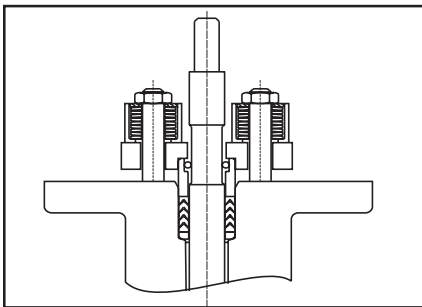

Emission-Pak Live-loaded Packing

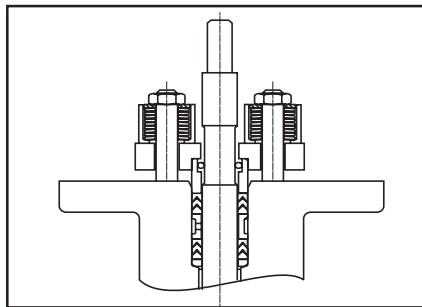

Emission-Pak Live-loaded Packing With Double Packing

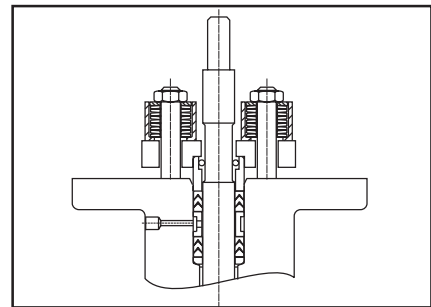

Emission-Pak Live-loaded Packing With Double Packing And Monitoring Port

Note *All Emission-Pak illustrations depict a standard valve with PTFE V-ring packing.

Steam service

Wafer-Sphere butterfly valves are well-suited for a wide range of steam applications. These range from PTFE-seated valves capable of handling lower pressure to valves with Xtreme seats. Ratings of Wafer-Sphere valves in this bulletin for on-off steam service are as follows: Valves may be derated based on shaft material selection.

Valve type	Seat material	Maximum pressure differential	
		psi	bar
815W, 815L	Xtreme	200*	14*
830W, 830L	Xtreme	450	31

* Max. rating of carbon steel body per ASME B16.34 at corresponding saturated steam temperature.

Cryogenic service

Using Wafer-Sphere with unique polymeric and polymeric/metal composite seats, cryogenic Wafer-Sphere valves are rated to give tight, reliable shutoff on service extending from -320°F (-196°C) to ambient condition at pressures up to 1440 psi (99 bar). Cryogenic seats for valve sizes 3" – 12" (DN 80 – 300) are composite. Seats for sizes 14" – 48" (DN 350 – 1200) are Kel-F® material. See Bulletin W130-1.

Chlorine service

Wafer-Sphere valves reliably control the flow of both liquid and gaseous chlorine. The patented seat design insures positive, leaktight shutoff of this lethal substance. A range of key materials permits selection of the Wafer-Sphere valve best suited for the moisture content of the chlorine that is to be handled. Valves for chlorine service are specially cleaned to preclude possible reaction of the chlorine to foreign substances. For further information see Bulletin W150-2.

Oxygen service

Wafer-Sphere valves are available specially prepared for oxygen service, capable of filling a wide range of applications that include both on-off operation and proportional control. A rigid procedure is followed in preparing components, assembling, testing, and packaging these valves to assure cleanliness and to avoid the inherent danger of oxygen's reaction with grease, oil or other foreign matter. Bulletin W150-3 contains additional details.

NACE service

ASME Class 150 and 300 Wafer-Sphere valves are available to comply with the NACE MR0103 standard. These valves are well suited for oil and gas industry applications requiring sulfide stress cracking resistant metallic materials.

Abrasive service

For applications involving slurries or gas-borne solid particles, Wafer-Sphere valves are available with the disc hard-coated with tungsten titanium carbide (TTC). Service life of the valve is increased significantly with the assurance of extended sealing capability. This hard coating is also available on application on other valve components that may be subject to wear in other unusual process conditions.

Vacuum service

Standard Wafer-Sphere valves are rated for tight shut-off of vacuum to 2×10^{-2} torr. Special high vacuum Wafer-Sphere valves can be provided for vacuums to 1×10^{-5} torr. Additionally, high vacuum valves can be certified to have a leakage rate not to exceed 1×10^{-5} cc/sec. of helium at 1×10^{-5} torr vacuum. Refer to Bulletin W150-4 for details.

High-Cycle option

Testing in the Valmet R&D laboratories indicates that a combination of components, including Xtreme (X) seat, filled super PTFE shaft seals, 316 SS/Woven PTFE shaft bearings, PEEK®-filled PTFE thrust bearings and excluder

rings, yields significantly longer life than a standard configuration valve. Actual cycle performance is subject to media, pressure, and temperature conditions. Applications such as oxygen, nitrogen, hydrogen, water, and other clean media are ideally suited for this option.

Operating handles and actuators

As an option, handles are available for smaller sizes of the Wafer-Sphere high-performance butterfly valve. We recommend that manual-gear, pneumatic, or electric actuators be used at differential pressures higher than the

values listed below. All handles have locking capability. Locking device designed to use 5/16” diameter shank to allow for proper engagement of the level.

Handle Operated Series 815											
Valve size		Valve type	Maximum differential pressure				Handle length		Handle weight		Handle code
			T, M, U or X Seats		Fire-Tite Seat						
Inches	DN		psi	bar	psi	bar	inches	mm	lb.	kg	
2-1/2	65	815W/815L	285	19.7	285	19.7	11	279	3	1.3	WSH-36
3	80	815W/815L	285	19.7	285	19.7	11	279	3	1.3	WSH-36
4	100	815W/815L	285	19.7	285	19.7	11	279	3	1.3	WSH-36
5	125	815W/815L	150	10.3	—	—	11	279	3	1.3	WSH-36
6	150	815W/815L	150	10.3	—	—	11	279	3	1.3	WSH-38
8	200	815W/815L	150	10.3	—	—	22	559	15	6.8	WSH-23
10	250	815W/815L	50	3.4	—	—	22	559	15	6.8	WSH-24
12	300	815W/815L	50	3.4	—	—	22	559	15	6.8	WSH-25

Handle Operated Series 830											
Valve size		Valve type	Maximum differential pressure				Handle length		Handle weight		Handle code
			T, M, U or X Seats		Fire-Tite Seat						
Inches	DN		psi	bar	psi	bar	inches	mm	lb.	kg	
2-1/2	65	830L	300	20.7	—	—	11	279	3	1.3	WSH-36
3	80	830W/830L	300	20.7	300	20.7	11	279	3	1.3	WSH-36
4	100	830W/830L	300	20.7	300	20.7	11	279	3	1.3	WSH-36
5	125	830L	300	20.7	—	—	11	279	3	1.3	WSH-38
6	150	830W/830L	150	10.3	—	—	22	559	15	6.8	WSH-23
8	200	830W/830L	150	10.3	—	—	22	559	15	6.8	WSH-24
10	250	830W/830L	50	3.4	—	—	22	559	15	6.8	WSH-25

Materials of Construction for Handle Kits			
Part number*	Part name	Handle code	
		WSH-36	WSH-23
H1	Handle Subassembly	Stainless steel	Malleable iron
H2	Ratchet	Stainless steel	Carbon steel
H3	Cap Screw	Stainless steel	Carbon steel
H4	Lock Washer	—	Carbon steel
H5	Hex Nut	—	Carbon steel
H6	Cap Screw	Stainless steel	Carbon steel
H7	Lock Washer	Stainless steel	Carbon steel

* Refer to drawing on pages 11 and 12.

Valve torque data

The torque required to open or close the Series 815 and Series 830 can easily be calculated using the equation on the following page. However, for your convenience, the following tables can be used as a quick guide for actuator selection. If the valve's torque is not listed in the tables, **use**

the equation on next page to calculate the torque. Refer to other bulletins for pneumatic and electric actuators. Select an actuator that provides the same or greater torque output than the valve's torque. **If in doubt, select the next larger actuator.**

Valve size		Torque – Series 815 Shaft Downstream; T, M, U, & X Seats					
		Shut-off differential pressure					
Inches	DN	FT•LBS @ 100 psi	N•m @ 6.9 bar	FT•LBS @ 200 psi	N•m @ 13.8 bar	FT•LBS @ 285 psi	N•m @ 19.7 bar
2-1/2	65	21	29	23	31	24	33
3	80	25	34	27	37	29	39
4	100	35	47	39	53	43	58
5	125	48	65	56	76	63	86
6	150	72	97	83	113	93	126
8	200	121	164	142	193	160	217
10	250	163	222	202	274	234	318
12	300	214	290	287	390	350	475
14	350	362	491	505	684	626	849
16	400	463	628	646	876	802	1087
18	450	602	816	844	1144	1050	1423
20	500	810	1098	1140	1546	1421	1926
24	600	1234	1673	1758	2384	2200	2983
30	750	2170	2942	2940	3986	3595	4873
36	900	3530	4786	4860	6589	5990	8121
42	1050	5780	7837	8060	10928	10000	13558
48	1200	9170	12433	12840	17409	15960	21638
54	1350	12950	17558	17900	24269	22110	29977
60	1500	19020	25790	26040	35310	32000	43397

Valve size		Torque – Series F815 Shaft Downstream or Upstream; All Fire-Tite Seats					
		Shut-off differential pressure					
Inches	DN	FT•LBS @ 100 psi	N•m @ 6.9 bar	FT•LBS @ 200 psi	N•m @ 13.8 bar	FT•LBS @ 285 psi	N•m @ 19.7 bar
2-1/2	65	42	57	45	61	47	64
3	80	53	72	57	77	59	81
4	100	67	91	74	100	80	108
5	125	97	132	114	155	128	174
6	150	131	178	152	206	170	230
8	200	218	296	256	347	288	391
10	250	333	452	406	550	468	635
12	300	508	689	636	862	745	1010
14	350	604	819	758	1028	889	1205
16	400	710	963	920	1247	1099	1489
18	450	970	1315	1370	1857	1710	2318
20	500	1390	1885	1980	2685	2482	3364
24	600	2050	2779	2700	3661	3353	4410
30	750	2920	3959	3940	5342	4807	6517
36	900	3530	4786	4960	6725	6176	8373
42	1050	5620	7620	7440	10087	8987	12185
48	1200	8800	11931	12100	16405	14905	20208

Valve size		Torque – Series 830 Shaft Downstream; T, M, U, & X Seats											
		Shut-off differential pressure											
Inches	DN	FT•LBS @ 300 psi	N•m @ 20.7 bar	FT•LBS @ 400 psi	N•m @ 27.6 bar	FT•LBS @ 500 psi	N•m @ 34.5 bar	FT•LBS @ 600 psi	N•m @ 41.4 bar	FT•LBS @ 700 psi	N•m @ 48.3 bar	FT•LBS @ 740 psi	N•m @ 51 bar
2-1/2	65	25	34	27	36	30	41	33	45	35	47	36	49
3	80	31	42	34	46	38	51	41	55	44	60	45	62
4	100	52	70	58	79	65	88	72	97	78	106	81	110
5	125	85	115	98	132	112	151	125	169	138	186	143	193
6	150	119	161	138	188	158	214	178	241	197	267	205	278
8	200	231	313	271	368	312	422	352	477	392	532	408	554
10	250	354	480	422	572	490	664	557	756	625	848	652	885
12	300	492	667	582	790	673	913	764	1035	854	1158	890	1207
14	350	824	1117	1012	1372	1200	1627	1388	1882	1576	2137	1651	2239
16	400	989	1340	1212	1643	1435	1946	1658	2248	1881	2550	1970	2671
18	450	1279	1734	1562	2118	1845	2502	2128	2885	2411	3269	2524	3422
20	500	1707	2314	2096	2842	2485	3369	2874	3897	3263	4424	3419	4635
24	600	2309	3131	2832	3840	3355	4549	3878	5258	4401	5967	4610	6251
30	750	4210	5708	5080	6888	5950	8067	6820	9247	7690	10426	8038	10898
36	900	7220	9789	8760	11877	10300	13965	11840	16053	13380	18141	13996	18976

Valve torque data (continued)

Valve size		Torque – Series F830 Shaft Downstream or Upstream; All Fire-Tite Seats											
		Shut-off differential pressure											
Inches	DN	FT•LBS @ 300 psi	N•m @ 20.7 bar	FT•LBS @ 400 psi	N•m @ 27.6 bar	FT•LBS @ 500 psi	N•m @ 34.5 bar	FT•LBS @ 600 psi	N•m @ 41.4 bar	FT•LBS @ 700 psi	N•m @ 48.3 bar	FT•LBS @ 740 psi	N•m @ 51 bar
3	80	57	77	58	79	60	81	61	83	63	85	63	86
4	100	86	117	94	127	102	138	110	149	118	160	121	164
6	150	189	256	212	287	235	319	258	350	281	381	290	394
8	200	313	424	354	480	395	536	436	591	477	647	493	669
10	250	464	629	522	708	580	786	638	865	696	944	719	975
12	300	825	1119	960	1302	1095	1485	1230	1668	1365	1851	1419	1924
14	350	922	1250	1076	1459	1230	1668	1384	1877	1538	2085	1600	2169
16	400	1170	1586	1390	1885	1610	2183	1830	2481	2050	2779	2138	2899
18	450	1980	2685	2440	3308	2900	3932	3360	4556	3820	5179	4004	5429
20	500	2800	3796	3460	4691	4120	5586	4780	6481	5440	7376	5704	7734
24	600	4400	5966	5400	7321	6400	8677	7400	10033	8400	11389	8800	11931

Torque equation

Use the following equation to calculate the torque required to open and close the Series 815 and Series 830 valves.

Torque required (FT•LBS) = (Kt multiplied by the shut-off differential pressure in psi) + Ts

EXAMPLE: 6" (DN 150) 815W-11-36HBMT at 230 psi (15.9 bar) differential pressure, installed shaft downstream = (0.116 X 230) + 60 = 87 FT•LBS.

To convert FT•LBS to N•m, multiply by 1.356.

Valve size		Class 150					Class 300				
		Series 815 T, M, U, & X Seats			Series 815 Fire-Tite		Series 830 T, M, U, & X Seats			Series 830 Fire-Tite	
Inches	DN	Kt Shaft Upstream	Kt Shaft Downstream	Ts	Kt Shaft Upstream or Downstream	Ts	Kt Shaft Upstream	Kt Shaft Downstream	Ts	Kt Shaft Upstream or Downstream	Ts
2-1/2	65	0.017	0.014	20	0.024	40	0.027	0.026	17	—	—
3	80	0.021	0.021	23	0.033	50	0.034	0.033	21	0.015	52
4	100	0.046	0.046	30	0.07	60	0.068	0.066	32	0.08	62
5	125	0.105	0.081	40	0.13	65	0.130	0.125	47	—	—
6	150	0.156	0.116	60	0.21	110	0.203	0.196	60	0.23	120
8	200	0.301	0.211	100	0.38	180	0.423	0.403	110	0.41	190
10	250	0.584	0.384	125	0.73	260	0.689	0.679	150	0.58	290
12	300	0.847	0.737	140	1.28	380	1.106	0.906	220	1.35	420
14	350	2.034	1.424	220	1.54	450	2.28	1.88	260	1.54	460
16	400	2.88	1.83	280	2.1	500	3.21	2.23	320	2.2	510
18	450	3.65	2.42	360	4.0	570	3.94	2.83	430	4.6	600
20	500	4.72	3.30	480	5.9	800	5.01	3.89	540	6.6	820
24	600	7.34	5.24	710	7.5	1400	6.88	5.23	740	10	1400
30	750	11.2	7.7	1400	12.0	1900	9.4	8.7	1600	—	—
36	900	20.4	13.3	2200	21.0	2400	16.1	15.4	2600	—	—
42	1050	29.9	22.8	3500	31.0	3800	—	—	—	—	—
48	1200	43.7	36.7	5500	45.0	5700	—	—	—	—	—
54	1350	59.5	49.5	8000	—	—	—	—	—	—	—
60	1500	80.7	70.2	12000	—	—	—	—	—	—	—

Note: The Ts value for a valve with Emission-Pak Live-Loaded Packing will increase. For valves with Live-Loaded PTFE shaft packing, use (Ts x 1.06). For valves with Live-Loaded Graphite shaft packing, use (Ts x 1.26).

Bills of materials and parts list				
Series 815				
Part no.	Part name	Type 815_2236 815_22HB F815_2236 F815_22HB	Type 815_2271 F815_2271	Type 815_3600 815_36HB F815_3600 F815_36HB
1	Body	Carbon steel ASTM A216, Type WCB		316 Stainless steel ASTM A351, Type CF8M
2	Insert	Carbon steel		316 Stainless steel
3	Disc	316 Stainless steel	Monel	316 Stainless steel
4	Shaft	316 Stainless steel (2236) or 17-4 PH Stainless steel (22HB)		316 Stainless steel (3600) or 17-4 PH SS (36HB)
5	Seat†	See page 19 for seat codes		
6	Shaft Bearing	PTFE composite backed with 316 Stainless steel	PTFE composite backed with Monel	PTFE composite backed with 316 Stainless steel
7	Spacer	Stainless steel	Monel	Stainless steel
8	Shaft Seal†	See page 19 for seal codes		
9	Compression Ring	316 Stainless steel		
10	Compression Plate	Carbon steel		316 Stainless steel
13	Disc Pin	Same material as shaft		
14	Stud	Carbon steel		Stainless steel
15	Nut	Carbon steel		Stainless steel
16	Lockwasher (16" [DN 400] and larger only)	Carbon steel		Stainless steel
17	Name Plate	Stainless steel		
18	Drive Screw	Stainless steel		
21	Cap Screw (815L & 14" - 60" [DN 350 - 1500] 815W)	Stainless steel		
26	Indicator Plate (42" - 60" [DN 1050 - 1500] only)	Stainless steel		
27	Drive Screw (42" - 60" [DN 1050 - 1500] only)	Stainless steel		
29	Indicator Pointer (16" - 60" [DN 400 - 1500] only)	Carbon steel		
40	Body Seal†	PTFE (2-1/2" - 4" [DN 65 - 100] standard 815Ls only) or graphite (3" - 12" [DN 80 - 300] Fire-Tite)		
41	Top Bearing Spacer (2-1/2" - 10" [DN 65 - 250])	PTFE		
47	Retaining Ring (2-1/2" - 36" [DN 65 - 900] only)	Inconel®		
53	Cover Plate (14" - 36" [DN 350 - 900])	Stainless steel or Carbon steel (Fire-Tite)		Stainless steel
54	Gasket (14" - 60" [DN 350 - 1500] only)	PTFE or graphite (Fire-Tite)		
55	Cap Screw (14" - 60" [DN 350 - 1500] only)	Stainless steel or Carbon steel (Fire-Tite)		Stainless steel
56	Lock Washer (14" - 60" [DN 350 - 1500] only)	Carbon steel		Stainless steel
64	Thrust Bearing	316 Stainless steel	Monel	316 Stainless steel
77	Insert Spring (2-1/2" - 12" [DN 65 - 300] 815Ws)	Inconel		

† Recommended spare part

Bills of materials and parts list				
Series 815				
Part no.	Part name	Type 815_3500 F815_3500	Type 815_3635 F815_3635	Type 815_7100 F815_7100
1	Body	Alloy 20 Stainless steel ASTM A351-Type CN7M	316 Stainless steel ASTM A351-Type CF8M	Monel ASTM A494
2	Insert	Alloy 20	316 Stainless steel	Monel
3	Disc	Alloy 20		Monel
4	Shaft	Alloy 20		Monel
5	Seat†	See page 19 for seat codes		
6	Shaft Bearing	PTFE composite backed with Alloy 20 Stainless steel		PTFE composite backed with Monel
7	Spacer	Alloy 20		Monel
8	Shaft Seal†	See page 19 for seal codes		
9	Compression Ring	316 Stainless steel		
10	Compression Plate	316 Stainless steel	316 Stainless steel	Monel
13	Disc Pin	Same material as shaft		
14	Stud	Stainless steel		Monel
15	Nut	Stainless steel		Monel
16	Lockwasher (16" [DN 400] and larger)	Carbon steel		Monel
17	Name Plate	Stainless steel		
18	Drive Screw	Stainless steel		
21	Cap Screw (815L & 14" – 60" [DN 350 – 1500] 815W)	Stainless steel		Monel
26	Indicator Plate (42" – 60" [DN 1050 – 1500] only)	Stainless steel		
27	Drive Screw (42" – 60" [DN 1050 – 1500] only)	Stainless steel		
29	Indicator Pointer (16" – 60" [DN 400 – 1500] only)	Carbon steel		
40	Body Seal†	PTFE (2-1/2" – 4" [DN 65–100] standard 815Ls only) or graphite (3" – 12" [DN 80 – 300]) (Fire-Tite)		
41	Top Bearing Spacer (2-1/2" – 10" [DN 65 – 250])	PTFE		
47	Retaining Ring (2-1/2" – 36" [DN 65 – 900] only)	Inconel		
53	Cover Plate (14" – 60" [DN 350 – 1500])	Alloy 20	Stainless steel	Monel
54	Gasket (14" – 60" [DN 350 – 1500] only)	PTFE or graphite (Fire-Tite)		
55	Cap Screw (14" – 60" [DN 350 – 1500] only)	Stainless steel		Monel
56	Lock Washer (14" – 60" [DN 350 – 1500] only)	Stainless steel		Monel
64	Thrust Bearing	Alloy 20		Monel
77	Insert Spring (2-1/2" – 12" [DN 65 – 300] 815Ws)	Inconel		

† Recommended spare part

Bills of materials and parts list					
Series 830					
Part no.	Part name	Type 830_22HB F830_22HB	Type 830_2271 F830_2271	Type 830_36HB F830_36HB	Type 830_3635 F830_3635
1	Body	Carbon steel (3" - 12" [DN 80 - 300]) ASTM A216, Type WCB [14" - 24" [DN 350 - 600]]		316 Stainless steel ASTM A351, Type CF8M	
2	Insert	Carbon steel		316 Stainless steel	
3	Disc	316 Stainless steel	Monel	316 Stainless steel	Alloy 20
4	Shaft	17-4 PH Stainless steel	Monel	17-4 PH SS	Alloy 20
5	Seat†	See page 19 for seat codes			
6	Shaft Bearing	PTFE composite backed with 316 SS	PTFE composite backed with Monel	PTFE composite backed with 316 SS	PTFE composite backed with Alloy 20
7	Spacer	Stainless steel	Monel	316 Stainless steel	Alloy 20
8	Shaft Seal†	See page 19 for seal codes			
9	Compression Ring	316 Stainless steel			
10	Top Compression Plate	Carbon steel		316 Stainless steel	
13	Disc Pin	Same material as shaft			
14	Stud	Carbon steel		Stainless steel	
15	Nut	Carbon steel		Stainless steel	
16	Lock Washer (14" - 36" [DN 350 - 900] only)	Carbon steel			
17	Name Plate	Stainless steel			
18	Drive Screw	Stainless steel			
21	Cap Screw (830L & 14" - 24" [DN 350 - 600] 830W)	Stainless steel			
26	Indicator Plate (30" - 36" [DN 750 - 900])	Stainless steel			
27	Drive Screw (30" - 36" DN 750 - 900)	Stainless steel			
29	Indicator Pointer (14" - 36" [DN 350 - 900])	Carbon steel			
40	Body Seal†	PTFE (3" - 4" [DN 80 - 100] standard 830L only) or graphite (3" - 12" [DN 80 - 100] Fire-Tite)			
41	Top Bearing Spacer (except 12" [DN 15])	PTFE			
43	Bottom Bearing Spacer (14" - 16" [DN 350 - 400] only)	PTFE			
47	Retaining Ring (3" - 24" [DN 80 - 600] only)	Inconel			
53	Cover Plate	Carbon steel		316 Stainless steel	
54	Gasket	PTFE or graphite (Fire-Tite)			
55	Cap Screw	Carbon steel		Stainless steel	
56	Lock Washer	Carbon steel		Stainless steel	
64	Thrust Bearing	316 Stainless steel	Monel	316 Stainless steel	Alloy 20
77	Insert Spring (2-1/2" - 12" [DN 65 - 300] 830W only)	Inconel			

† Recommended spare part

Dimensions

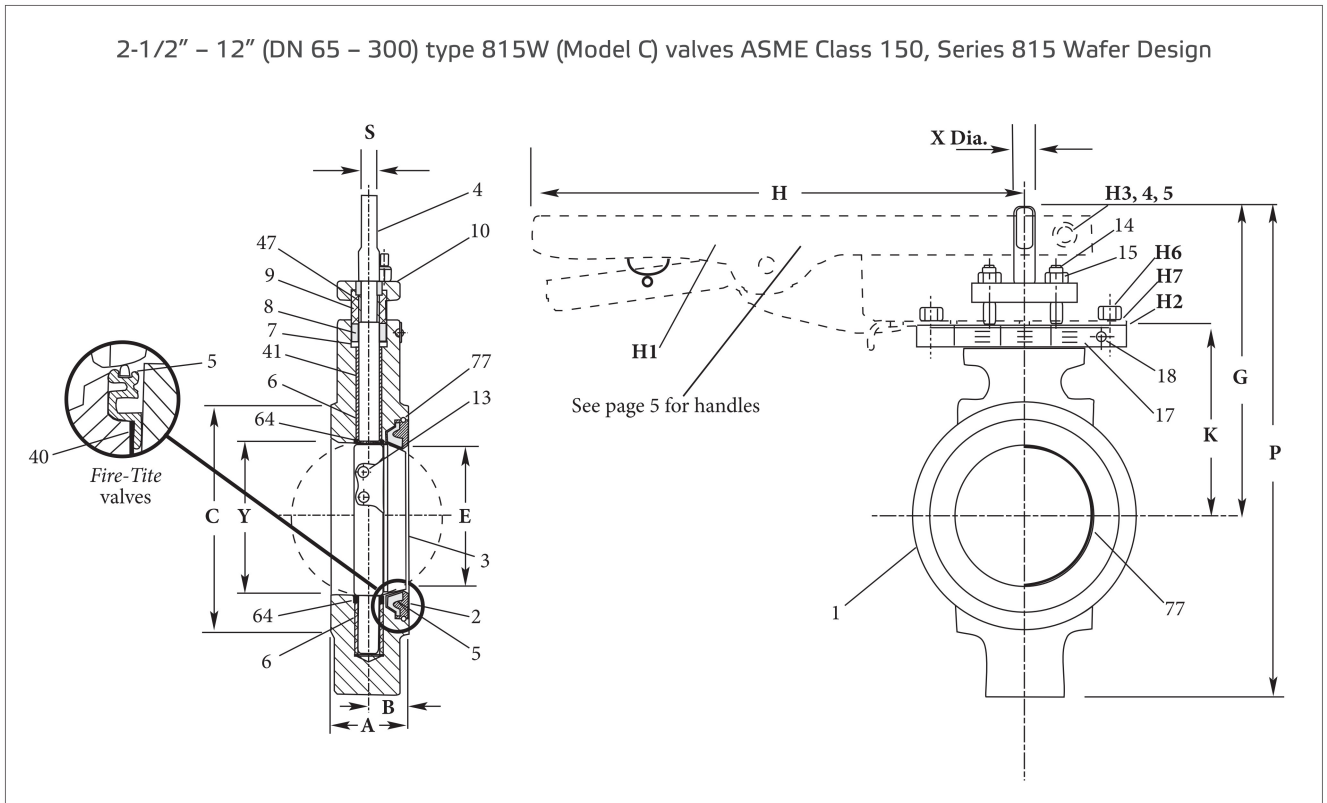

Valve size inches	Approximate dimensions – inches											Approx. weight lbs.**
	A	B	C	E	G	H	K	P	S Blade	X	Y*	
2-1/2	1.94	1.06	4.69	2.31	7.63	11.00	4.38	10.81	0.44	0.63	1.88	11
3	1.94	1.06	5.19	2.88	8.00	11.00	4.75	12.44	0.44	0.63	2.90	13
4	2.13	1.19	6.19	3.75	8.50	11.00	5.25	13.44	0.44	0.63	3.83	18
5	2.50	1.19	7.31	4.38	8.56	11.00	5.31	14.25	0.44	0.63	4.38	27
6	2.25	1.31	8.50	5.59	9.25	11.00	6.00	15.13	0.53	0.75	5.76	28
8	2.50	1.41	10.63	7.41	10.63	22.00	7.38	18.25	0.63	0.88	7.63	45
10	2.81	1.63	12.75	9.28	12.81	22.00	9.13	22.066	0.81	1.13	9.56	78
12	3.19	1.88	15.00	11.09	14.13	22.00	10.25	24.88	0.94	1.38	11.37	112

* Conforms to API 609 and MSS-SP 68 requirements for minimum clearances of pipe inside diameters for Schedule 80 pipe.

** Weights do not include handles. See page 5 for handle weights

Valve size DN	Approximate dimensions – mm											Approx. weight kg**
	A	B	C	E	G	H	K	P	S Blade	X	Y*	
65	49	27	119	59	194	279	111	275	11	16	48	5
80	49	27	132	73	203	279	121	316	11	16	74	6
100	54	30	157	95	216	279	133	341	11	16	97	8
125	64	30	186	111	217	279	135	362	11	16	111	12
150	57	33	216	142	235	279	152	384	13	19	146	13
200	64	36	270	188	270	559	187	464	16	22	194	20
250	71	41	324	236	325	559	232	560	21	29	243	35
300	81	48	381	282	359	559	260	632	24	35	289	51

* Conforms to API 609 and MSS-SP 68 requirements for minimum clearances of pipe inside diameters for Schedule 80 pipe.

** Weights do not include handles. See page 5 for handle weights

Dimensions (continued)

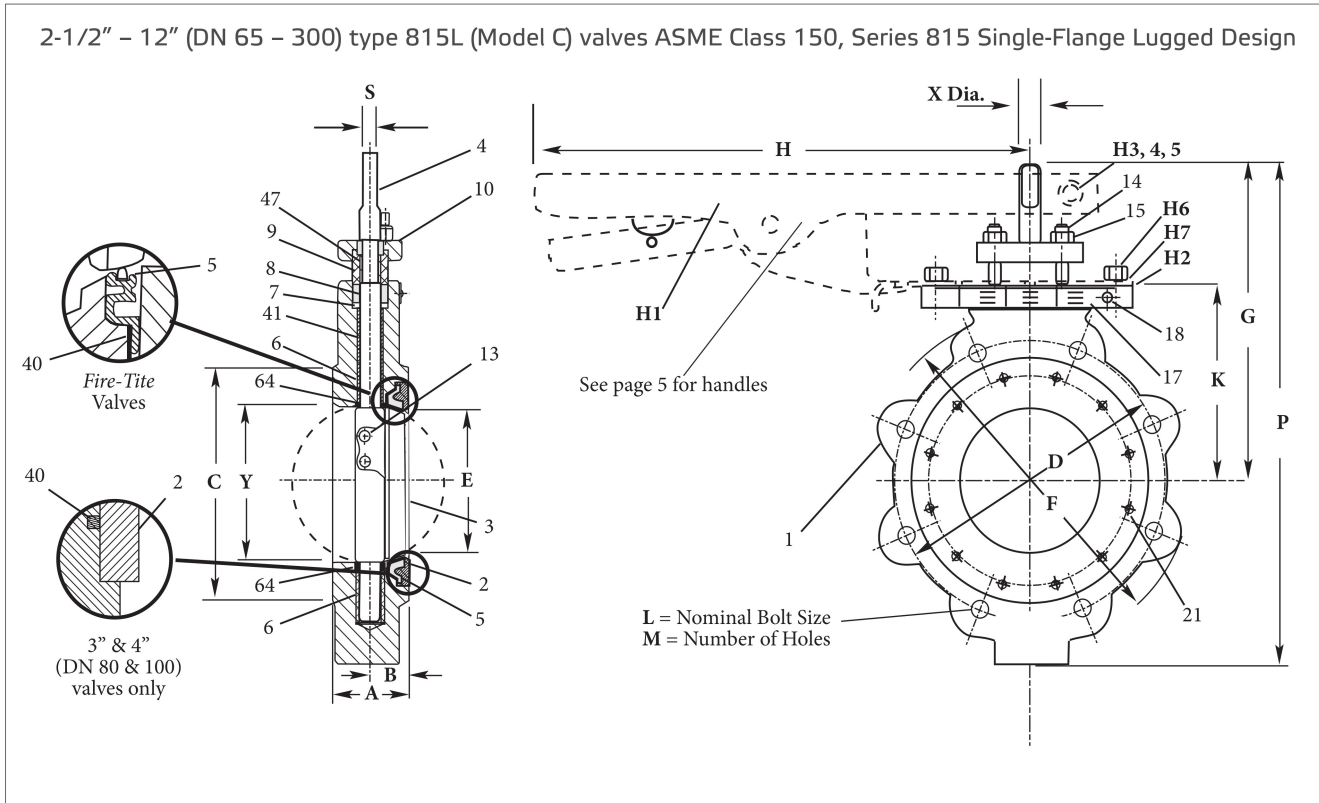

Valve size inches	Approximate dimensions – inches														Approx. weight lbs.**	
	A	B	C	D	E	F	G	H	K	L	M	P	S Blade	X		Y*
2-1/2	1.94	1.06	4.13	5.50	2.31	7.00	7.63	11.00	4.38	5/8-11	4	10.81	0.44	0.63	1.88	11
3	1.94	1.06	5.19	6.00	2.88	7.50	8.00	11.00	4.75	5/8-11	4	12.44	0.44	0.63	2.90	13
4	2.13	1.19	6.19	7.50	3.75	9.00	8.50	11.00	5.25	5/8-11	8	13.44	0.44	0.63	3.83	18
5	2.50	1.19	7.31	8.50	4.38	10.38	8.56	11.00	5.31	3/4-10	8	13.44	0.44	0.63	4.38	27
6	2.25	1.31	8.50	9.50	5.59	11.00	9.25	11.00	6.00	3/4-10	8	15.13	0.53	0.75	5.76	28
8	2.50	1.41	10.63	11.75	7.41	13.50	10.63	22.00	7.38	3/4-10	8	18.25	0.63	0.88	7.63	45
10	2.81	1.63	12.75	14.25	9.28	16.00	12.81	22.00	9.13	7/8-9	12	22.06	0.81	1.13	9.56	78
12	3.19	1.88	15.00	17.00	11.09	19.00	14.13	22.00	10.25	7/8-9	12	24.88	0.94	1.38	11.37	112

* Conforms to API 609 and MSS-SP 68 requirements for minimum clearances of pipe inside diameters for Schedule 80 pipe.

** Weights do not include handles. See page 5 for handle weights.

Valve size DN	Approximate dimensions – mm														Approx. weight kg**	
	A	B	C	D	E	F	G	H	K	L	M	P	S Blade	X		Y*
65	49	27	105	140	59	178	194	279	111	5/8-11	4	275	11	16	48	7
80	49	27	132	152	73	191	203	279	121	5/8-11	4	316	11	16	74	8
100	54	30	157	191	95	229	216	279	133	5/8-11	8	341	11	16	97	12
125	64	30	186	216	111	264	217	279	135	3/4-10	8	341	11	16	111	18
150	57	33	216	241	142	279	235	279	152	3/4-10	8	384	13	19	146	20
200	64	36	270	298	188	343	270	559	187	3/4-10	8	464	16	22	194	31
250	71	41	324	362	236	406	325	559	232	7/8-9	12	560	21	29	243	42
300	81	48	381	432	282	483	359	559	260	7/8-9	12	632	24	35	289	64

* Conforms to API 609 and MSS-SP 68 requirements for minimum clearances of pipe inside diameters for Schedule 80 pipe.

** Weights do not include handles. See page 5 for handle weights.

Dimensions (continued)

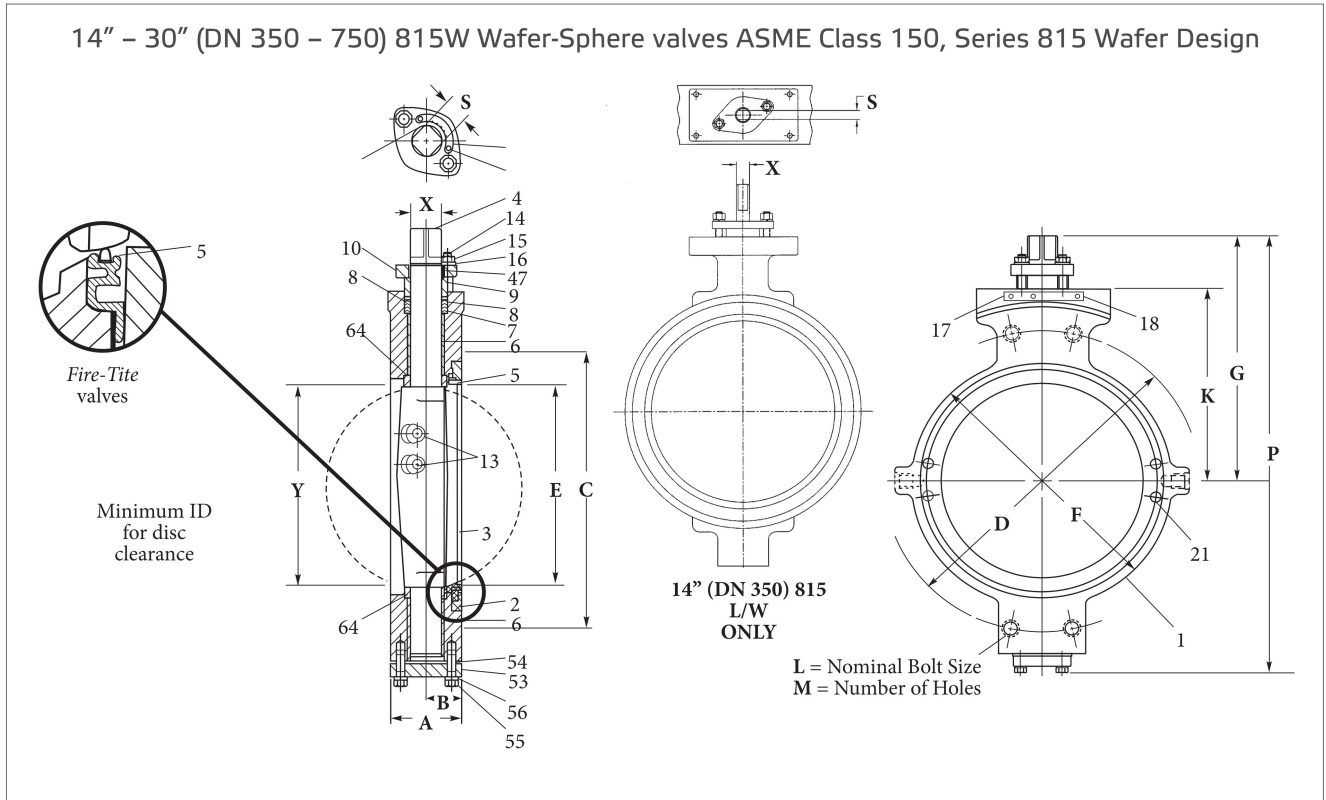

Valve size Inches	Approximate dimensions – inches														Approx. weight lbs.
	A	B	C	D	E	F	G	K	L	M**	P	S	X	Y	
14 [‡]	3.63	2.06	16.25	18.75	12.38	16.25	15.53	12.16	1-1/8*	0	27.75	1.13	1.63	12.50	181
16	4.00	2.22	18.50	21.25	14.28	18.50	16.56	13.06	1-1/16*	4	29.22	1.63	1.88	14.38	253
18	4.50	2.63	21.00	22.75	16.28	21.00	17.66	14.03	1-3/16*	4	31.56	1.63	2.13	16.38	345
20	5.00	2.63	23.00	25.00	17.94	23.00	18.38	14.88	1-1/8-8 [†]	4**	33.13	1.63	2.38	17.88	438
24	6.06	3.00	27.25	29.50	21.63	27.25	23.91	19.28	1-1/8-8 [†]	4**	45.69	2.00	2.75	21.34	735
30	6.56	3.44	33.75	36.00	27.63	33.75	27.44	22.44	1-1/8-8 [†]	4	51.44	2.00	3.50	28.00	1309

* Clearance instead of tapped holes

** Each side

† ASME B16.5 requires all bolts 1-1/8" (28.6 mm) and larger have an 8-UN thread series.

‡ 14" (DN 350) 815 L/W's have bladed shafts.

Valve size DN	Approximate dimensions – mm														Approx. weight kg
	A	B	C	D	E	F	G	K	L	M**	P	S	X	Y	
350 [‡]	92	52	413	476	314	413	394	309	1-1/8*	0	705	29	41	318	82
400	102	56	470	540	363	470	421	332	1-1/16*	4	742	41	48	365	115
450	114	67	533	578	414	433	449	356	1-3/16*	4	802	41	54	416	156
500	127	67	584	635	456	584	467	378	1-1/8-8 [†]	4**	842	41	60	454	199
600	154	76	692	749	549	692	607	490	1-1/8-8 [†]	4**	1161	51	70	542	333
750	167	87	857	914	702	857	697	570	1-1/8-8 [†]	4	1307	51	89	711	594

* Clearance instead of tapped holes

** Each side

† ASME B16.5 requires all bolts 1-1/8" (28.6 mm) and larger have an 8-UN thread series.

‡ 14" (DN 350) 815 L/W's have bladed shafts.

Dimensions (continued)

14" – 60" (DN 350 – 1500) 815L Wafer-Sphere valves ASME Class 150, Series 815 Single-Flanged Lugged Design

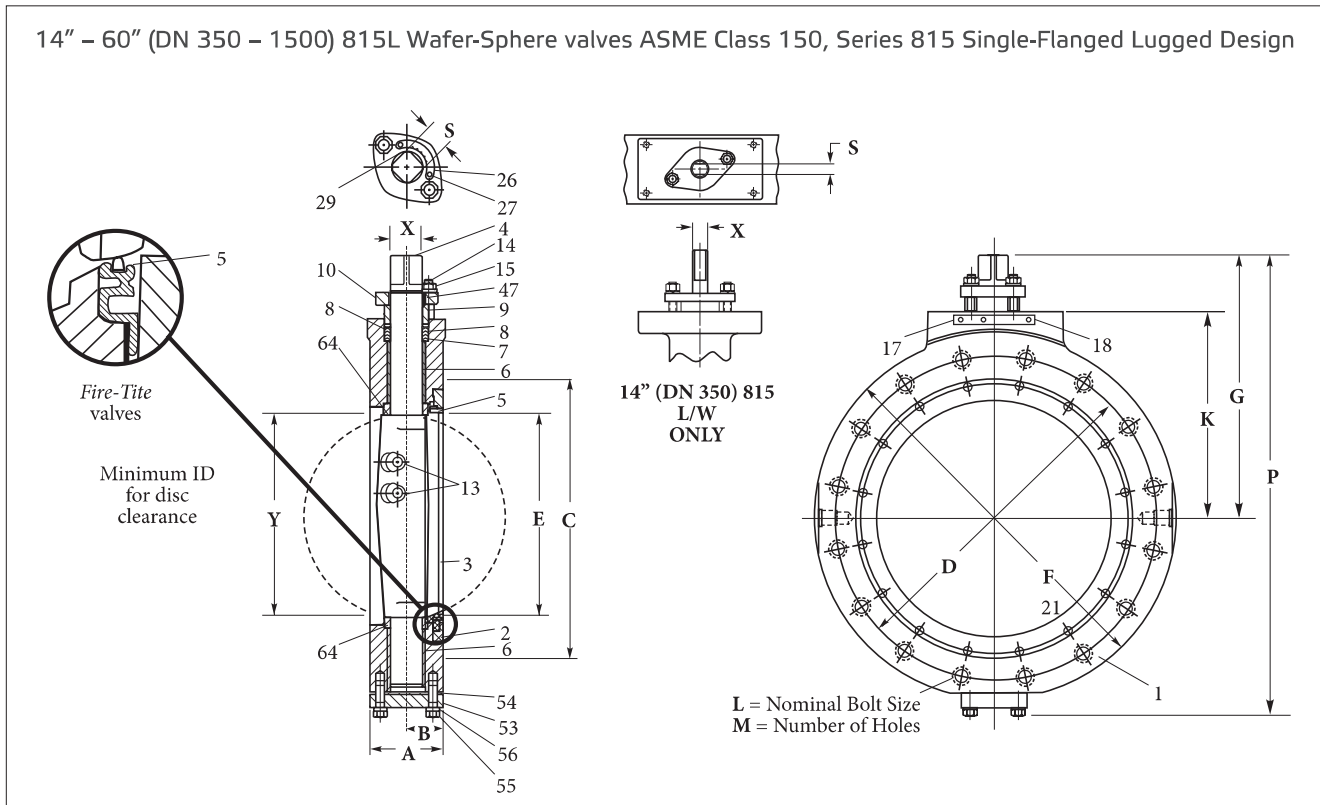

Valve size inches	Approximate dimensions – inches														Approx. weight lbs.
	A	B	C	D	E	F	G	K	L	M	P	S	X	Y	
14 ³	3.63	2.06	16.25	18.75	12.38	21.00	15.53	12.16	1-8	12	27.75	1.13	1.63	12.50	231
16	4.00	2.22	18.50	21.25	14.28	23.50	16.56	13.06	1-8	16	29.22	1.63	1.88	14.38	360
18	4.50	2.63	21.00	22.75	16.28	25.00	17.66	14.03	1-1/8-8 ¹	16	31.56	1.63	2.13	16.38	453
20	5.00	2.63	23.00	25.00	17.94	27.50	18.38	14.88	1-1/8-8 ¹	20	33.13	1.63	2.38	17.88	596
24	6.06	3.00	27.25	29.50	21.63	32.00	23.91	19.28	1-1/4-8 ¹	20	45.69	2.00	2.75	21.34	964
30	6.56	3.44	33.75	36.00	27.63	38.75	27.44	22.44	1-1/4-8 ¹	28	51.44	2.00	3.50	28.00	1634
36	7.25	3.63	40.25	42.75	34.88	46.00	31.25	26.00	1-1/2-8 ¹	32	56.38	2.00	4.00	34.50	2621
42	8.75	4.50	47.00	49.50	40.00	53.00	40.25	29.00	1-1/2-8 ¹	36	68.13	4.00 Dia ²	5.00	40.38	3800
48	10.00	5.13	53.50	56.00	46.00	59.50	44.50	33.25	1-1/2-8 ¹	44	76.88	5.00 Dia ²	5.50	46.19	4800
54	10.50	5.25	59.50	62.75	52.31	66.38	49.13	37.50	1-3/4-8 ¹	44	85.75	6.00 Dia ²	6.00	52.06	5800
60	11.00	5.75	66.00	69.25	57.94	73.00	54.75	41.13	1-3/4-8 ¹	52	95.38	6.00 Dia ²	6.50	57.81	7000

Valve size DN	Approximate dimensions – mm														Approx. weight kg
	A	B	C	D	E	F	G	K	L	M	P	S	X	Y	
350 ³	92	52	413	476	314	533	394	309	1-8	12	705	24	41	318	105
400	102	56	470	540	363	597	421	332	1-8	16	742	41	48	365	163
450	114	67	533	578	414	635	449	356	1-1/8-8 ¹	16	802	41	54	416	205
500	127	67	584	635	456	699	467	378	1-1/8-8 ¹	20	842	41	60	454	270
600	154	76	692	749	549	813	607	490	1-1/4-8 ¹	20	1161	51	70	542	437
750	167	87	857	914	702	984	697	570	1-1/4-8 ¹	28	1307	51	89	711	741
900	184	92	1022	1086	886	1022	794	660	1-1/2-8 ¹	32	1432	51	102	876	1189
1050	222	114	1194	1257	1016	1346	1067	737	1-1/2-8 ¹	36	1731	102 Dia ²	127	1026	1724
1200	254	130	1359	1422	1168	1511	1130	845	1-1/2-8 ¹	44	1953	127 Dia ²	140	1173	2177
1350	267	133	1511	1594	1329	1686	1248	953	1-3/4-8 ¹	44	2178	152 Dia ²	152	1322	2631
1500	279	146	1676	1759	1472	1854	1391	1045	1-3/4-8 ¹	52	2423	152 Dia ²	165	1468	3175

1 ASME B16.5 requires all bolts 1-1/8" (28.6 mm) and larger have 8-UN thread series.
 2 42" – 60" (DN 1050 – 1500) 815Ls have keyed shafts
 3 14" (DN 350) 815 L/W's have bladed shafts.

Dimensions (continued)

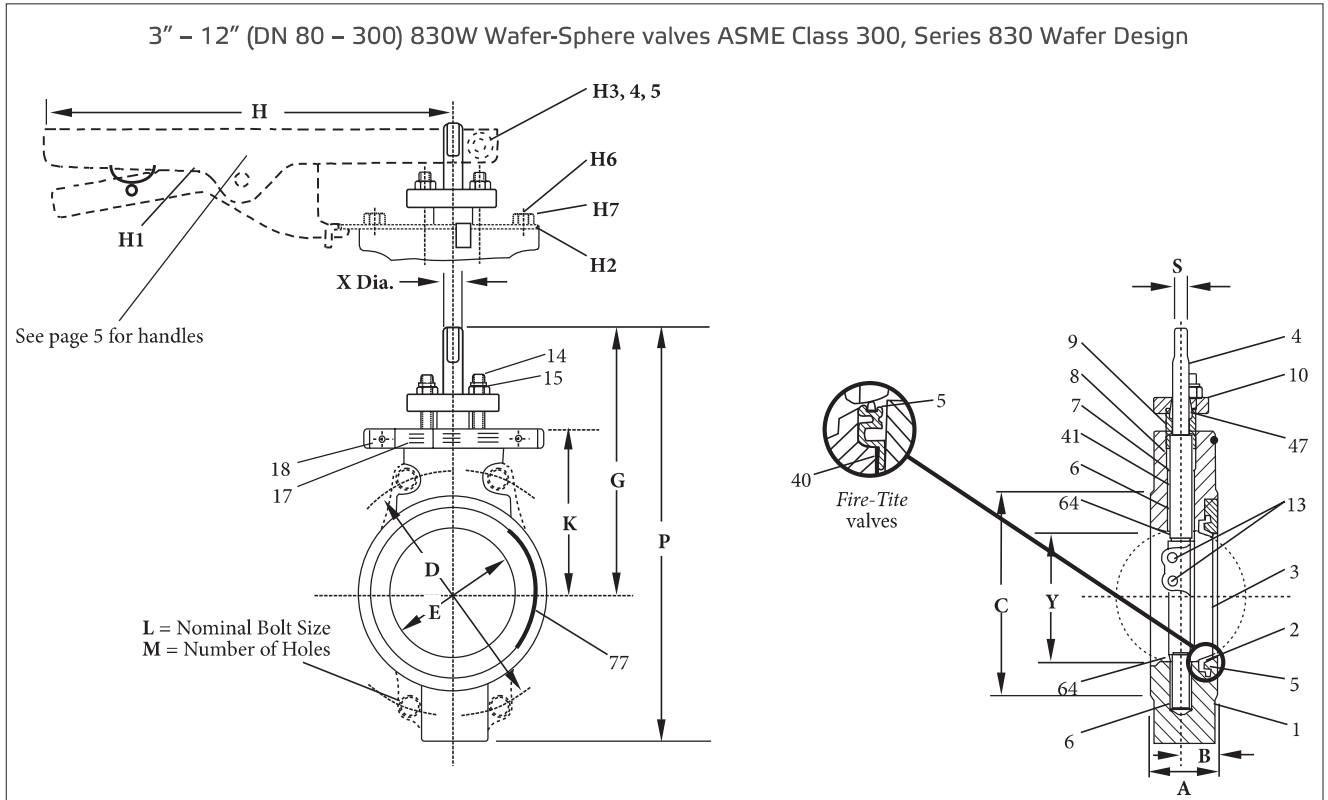

Valve size inches	Approximate dimensions – inches														Approx. weight lbs.**
	A	B	C	D	E	G	H	K	L	M	P	S	X	Y*	
3	1.94	1.06	5.19	—	2.88	8.00	11.00	4.75	—	—	12.44	0.44	0.63	2.90	13
4	2.13	1.19	6.19	—	3.75	8.50	11.00	5.25	—	—	13.44	0.44	0.63	3.83	18
6	2.31	1.34	8.50	—	5.59	10.13	22.00	6.88	—	—	16.25	0.63	0.88	5.76	32
8	2.88	1.56	10.63	—	7.41	12.06	22.00	8.38	—	—	19.50	0.81	1.13	7.63	60
10	3.25	1.75	12.75	15.25	9.28	13.88	22.00	10.00	1-8	4	23.31	0.94	1.38	9.56	106
12	3.63	1.97	15.00	17.75	11.09	15.31	—	13.13	1-1/8-8†	4	26.56	1.13	1.63	11.37	145

* Conforms to API 609 and MSS-SP 68 requirements for minimum clearances of pipe inside diameters for Schedule 80 pipe.

** Weights do not include handles. See page 5 for handle weights

† ASME B16.5 requires all bolts 1-1/8" (28.6 mm) and larger have 8-UN thread series.

Valve size DN	Approximate dimensions – mm														Approx. weight kg**
	A	B	C	D	E	G	H	K	L	M	P	S	X	Y*	
80	49	27	132	—	73	203	279	121	—	—	316	11	16	74	6
100	54	30	157	—	95	216	279	133	—	—	341	11	16	97	8
150	59	34	216	—	142	257	559	175	—	—	413	16	22	146	15
200	73	40	270	—	188	306	559	213	—	—	495	21	29	194	27
250	83	44	324	387	236	353	559	254	1-8	4	592	24	35	243	48
300	92	50	381	451	282	389	—	283	1-1/8-8†	4	675	29	41	289	66

* Conforms to API 609 and MSS-SP 68 requirements for minimum clearances of pipe inside diameters for Schedule 80 pipe.

** Weights do not include handles. See page 5 for handle weights

† ASME B16.5 requires all bolts 1-1/8" (28.6 mm) and larger have 8-UN thread series.

Dimensions (continued)

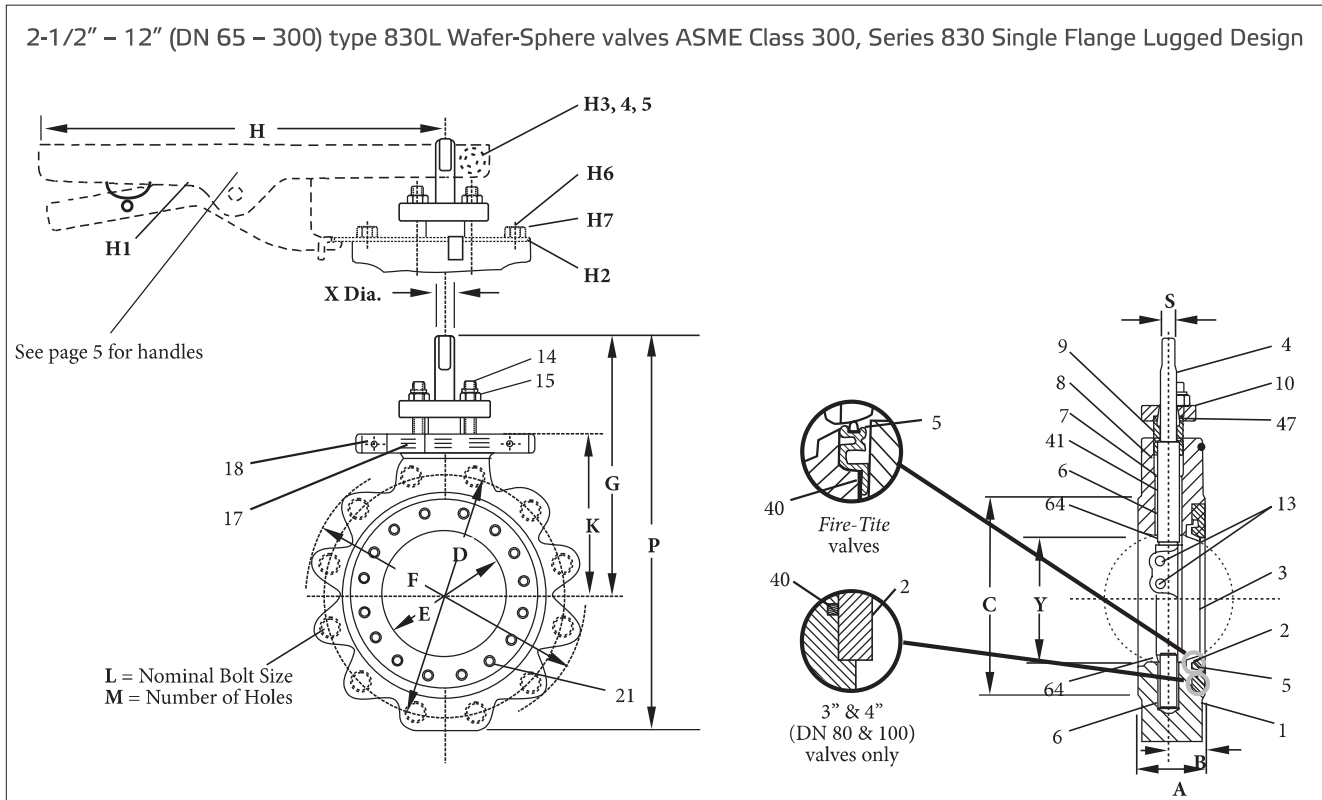

Valve size inches	Approximate dimensions – inches															Approx. weight lbs.**
	A	B	C	D	E	F	G	H	K	L	M	P	S	X	Y*	
2-1/2	1.94	1.06	4.13	5.88	2.38	7.50	7.63	11.00	4.38	3/4-10	8	11.19	0.44	0.63	1.88	16
3	1.94	1.06	5.19	6.63	2.88	8.13	8.00	11.00	4.75	3/4-10	8	12.44	0.44	0.63	2.90	20
4	2.13	1.19	6.19	7.88	3.75	9.38	8.50	11.00	5.25	3/4-10	8	13.44	0.44	0.63	3.83	29
5	2.50	1.31	7.31	9.25	4.38	10.97	9.25	11.00	6.03	3/4-10	8	14.25	0.53	0.75	4.38	41
6	2.31	1.34	8.50	10.63	5.59	12.13	10.13	22.00	6.88	3/4-10	12	16.25	0.63	0.88	5.76	52
8	2.88	1.56	10.63	13.00	7.41	15.00	12.06	22.00	8.38	7/8-9	12	19.50	0.81	1.13	7.63	92
10	3.25	1.75	12.75	15.25	9.28	17.50	13.88	22.00	10.00	1-8	16	23.31	0.94	1.38	9.56	160
12	3.63	1.97	15.00	17.75	11.09	20.25	15.31	—	11.13	1-1/8-8†	16	26.56	1.13	1.63	11.37	220

* Conforms to API 609 and MSS-SP 68 requirements for minimum clearances of pipe inside diameters for Schedule 80 pipe

** Weights do not include handles. See page 5 for handle weights

† ASME B16.5 requires all bolts 1-1/8" (28.6 mm) and larger have 8-UN thread series.

Valve size DN	Approximate dimensions – mm															Approx. weight kg**
	A	B	C	D	E	F	G	H	K	L	M	P	S	X	Y*	
65	49	27	105	149	60	191	194	279	111	3/4-10	8	284	11	16	48	7
80	49	27	132	168	73	207	203	279	121	3/4-10	8	316	11	16	74	9
100	54	30	157	200	95	238	216	279	133	3/4-10	8	341	11	16	97	13
125	64	33	186	235	111	279	235	279	153	3/4-10	8	362	13	19	111	19
150	59	34	216	270	142	308	257	559	175	3/4-10	12	413	16	22	146	24
200	73	40	270	330	188	381	306	559	213	7/8-9	12	495	21	29	194	42
250	83	44	324	387	236	445	353	559	254	1-8	16	592	24	35	243	73
300	92	50	381	451	282	514	389	—	283	1-1/8-8†	16	675	29	41	289	100

* Conforms to API 609 and MSS-SP 68 requirements for minimum clearances of pipe inside diameters for Schedule 80 pipe

** Weights do not include handles. See page 5 for handle weights

† ASME B16.5 requires all bolts 1-1/8" (28.6 mm) and larger have 8-UN thread series.

Dimensions (continued)

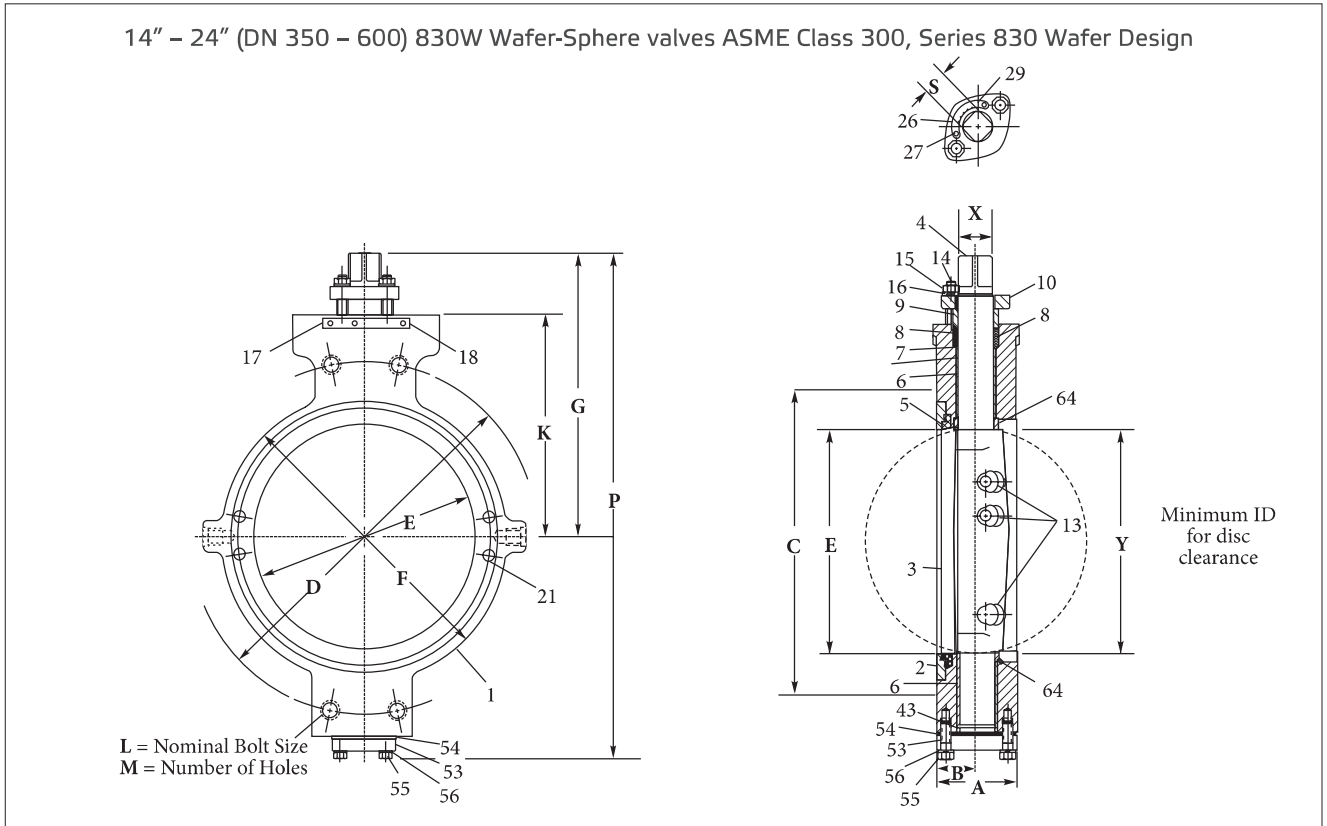

Valve size inches	Approximate dimensions – inches														Approx. weight lbs.
	A	B	C	D	E	F	G	K	L	M	P	S	X	Y	
14	4.63	2.31	16.25	20.25	12.38	16.25	16.43	12.80	1-1/8-8 [†]	4	28.75	1.63	2.13	11.75	368
16	5.25	2.44	18.50	22.50	14.31	18.50	17.31	13.80	1-1/4-8 [†]	4	30.75	1.63	2.13	13.63	429
18	5.88	2.94	21.00	24.75	16.28	21.00	21.34	16.71	1-1/4-8 [†]	4	37.80	2.00	2.75	15.44	715
20	6.38	3.19	23.00	27.00	17.91	23.00	22.58	17.58	1-1/4-8 [†]	4	39.95	2.00	3.50	17.06	896
24	7.25	3.63	27.25	32.00	21.63	27.25	24.96	19.71	1-1/2-8 [†]	4	44.93	2.00	4.00	20.63	1,390

[†] ASME B16.5 requires all bolts 1-1/8" (28.6 mm) and larger have 8-UN thread series.

Valve size DN	Approximate dimensions – mm														Approx. weight kg
	A	B	C	D	E	F	G	K	L	M	P	S	X	Y	
350	118	59	413	514	314	413	417	325	1-1/8-8 [†]	4	730	41	54	298	167
400	133	62	470	572	363	470	440	351	1-1/4-8 [†]	4	781	41	54	346	195
450	149	75	533	629	414	533	542	424	1-1/4-8 [†]	4	960	51	70	392	324
500	162	81	584	686	455	584	574	447	1-1/4-8 [†]	4	1015	51	89	433	406
600	184	92	692	813	549	692	634	501	1-1/2-8 [†]	4	1141	51	102	524	631

[†] ASME B16.5 requires all bolts 1-1/8" (28.6 mm) and larger have 8-UN thread series.

Dimensions (continued)

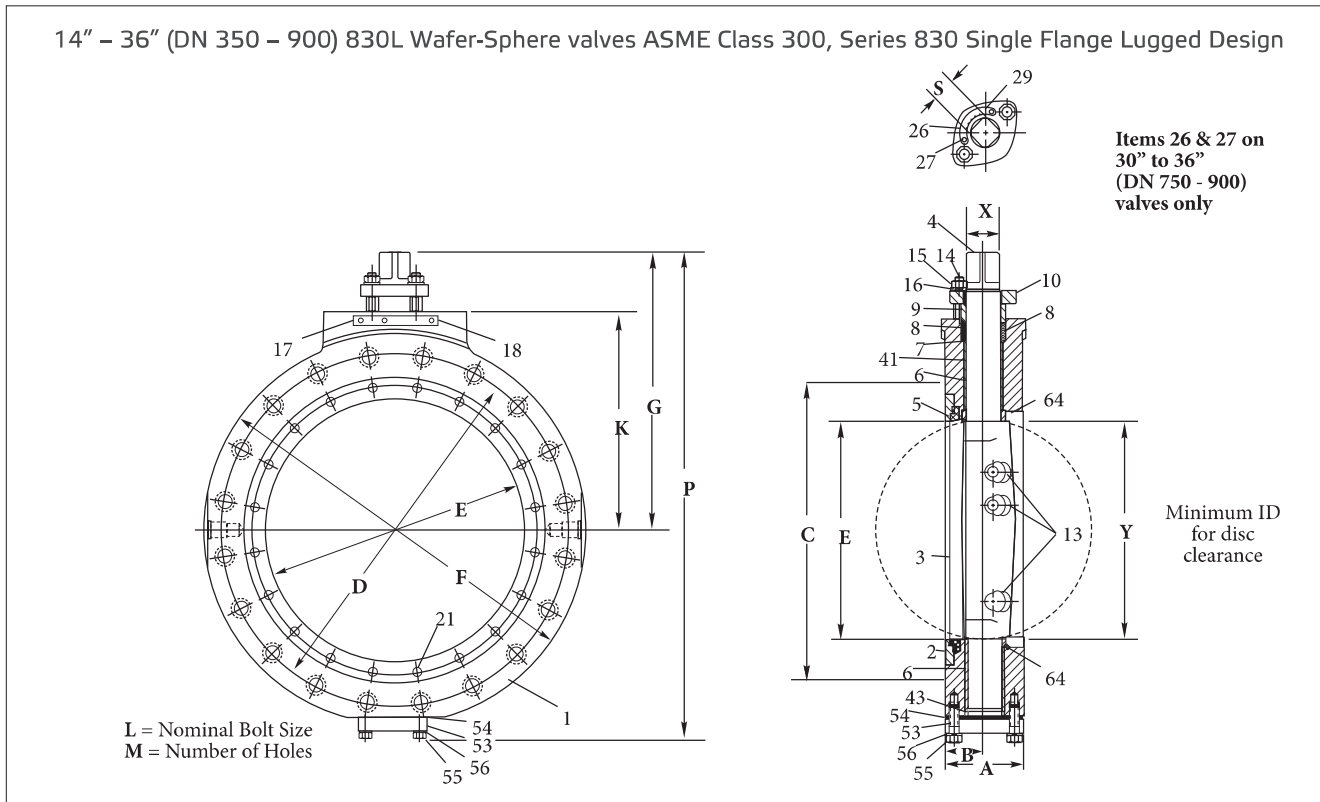

Valve size inches	Approximate dimensions – inches														Approx. weight lbs.
	A	B	C	D	E	F	G	K	L	M	P	S	X	Y	
14	4.63	2.31	16.25	20.25	12.38	23.00	16.43	12.80	1-1/8-8 [†]	20	28.75	1.63	2.13	11.75	557
16	5.25	2.44	18.50	22.50	14.31	25.50	17.31	13.80	1-1/4-8 [†]	20	30.75	1.63	2.13	13.63	724
18	5.88	2.94	21.00	24.75	16.28	28.00	21.34	16.71	1-1/4-8 [†]	24	37.80	2.00	2.75	15.44	1,110
20	6.38	3.19	23.00	27.00	17.91	30.50	22.58	17.58	1-1/4-8 [†]	24	39.95	2.00	3.50	17.06	1,428
24	7.25	3.63	27.25	32.00	21.63	36.00	24.96	19.71	1-1/2-8 [†]	24	44.93	2.00	4.00	20.63	2,170
30	10.75	5.38	33.75	39.25	27.69	43.00	36.31	25.28	1-3/4-8 [†]	28	61.00	3.50 Dia.*	5.50	28.75	2,800
36	11.25	5.63	40.25	46.00	34.88	50.00	41.44	30.81	2-8 [†]	32	71.80	4.00 Dia.*	6.00	35.00	3,400

[†] ASME B16.5 requires all bolts 1-1/8" (28.6 mm) and larger have 8-UN thread series.

* 30" and 36" (DN 50 – 900) 830Ls have keyed shaft.

Valve size DN	Approximate dimensions – mm														Approx. weight kg
	A	B	C	D	E	F	G	K	L	M	P	S	X	Y	
350	118	59	413	514	314	584	417	325	1-1/8-8 [†]	20	730	41	54	298	253
400	133	62	470	572	363	648	440	351	1-1/4-8 [†]	20	781	41	54	346	328
450	149	75	533	629	414	711	542	424	1-1/4-8 [†]	24	960	51	70	392	503
500	162	81	584	686	455	775	574	447	1-1/4-8 [†]	24	1015	51	89	433	648
600	184	92	692	813	549	914	634	501	1-1/2-8 [†]	24	1141	51	102	524	984
750	273	137	857	997	703	1092	922	642	1-3/4-8 [†]	28	1549	89 Dia.*	140	730	1270
900	286	143	1022	1168	886	1270	1053	783	2-8 [†]	32	1824	102 Dia.*	152	889	1542

[†] ASME B16.5 requires all bolts 1-1/8" (28.6 mm) and larger have 8-UN thread series.

* 30" and 36" (DN 50 – 900) 830Ls have keyed shaft.

WARNING: As the use of the valve is application specific, a number of factors should be taken into account when selecting a valve for a given application. Therefore, some of the situations in which the valves are used are outside the scope of this manual. If you have any questions concerning the use, application or compatibility of the valve with the intended service, contact Valmet for more information.

How to order series 815 and 830 Wafer-Sphere valves

These Wafer-Sphere valves are described by size and alpha-numeric code that defines body configuration, body, disc, shaft, seat, seal materials, and with options to denote special service and modifiers. Explanation of the code for valves in this bulletin is as follows:

EXAMPLE: The figure designation for a 6” ASME Class 150 single-flange lug-design valve, with double packing, monitoring port, carbon steel body, Monel disc and shaft, filled Xtreme seat, Carbon-filled enhanced PTFE shaft seal, and live-loaded shaft seals, is: **6” 815L DL-11-2271XZ-QY**.

1	2	3	4	5	6	7	8	9	10
6”	815	L	DL	11	22	71	XZ	C	QY

1	Size
2-1/2” – 60” (DN 65 – 1500)	See page 1 for specific availability

2	Pressure class
815	Standard ANSI Class 150
F815	Fire-Tite ANSI Class 150
818	Standard ANSI Class 150 w/CE Marking and Documentation
F818	Fire-Tite ANSI Class 150 w/CE Marking and Documentation
830	Standard ANSI Class 300
F830	Fire-Tite ANSI Class 300
838	Standard ANSI Class 300 w/CE Marking and Documentation
F838	Fire-Tite ANSI Class 300 w/CE Marking and Documentation

3	Body style
W	Wafer
L	Single-flange lugged

4	Special service
C	Chlorine
O	Oxygen
H	Hard-coated disc
HV	High vacuum
HVC	High vacuum certified
D	Double packing
DL	Double packing with monitoring port

5	Seat type
11	Standard (non-Fire-Tite)
31	Fire-Tite

6	Body material
22 ¹	Carbon steel
35	Alloy 20
36 ¹	316 Stainless steel
37 ¹	317 Stainless steel
71 ¹	Monel
73	Hastelloy C

7	Disc & shaft material
00 ^{2,4}	Same as body material
HB ¹	316 Stainless steel disc, 17-4 PH shaft
35	Alloy 20 disc and shaft
36	316 Stainless steel disc and shaft
37	317 Stainless steel
71 ¹	Monel disc and shaft
73	Hastelloy C disc and shaft

8	Seat & seal material
Standard	
TT	PTFE seat and seal
MT ⁵	Filled PTFE seat, PTFE seal
UU	UHMW polyethylene seat and seal
XZ	Xtreme seat & carbon-filled enhanced PTFE seal
Fire-Tite	
AE	PTFE/Stainless steel seat, graphite seal
AF	PTFE/Alloy 20 seat, graphite seal
AH	PTFE/Monel seat, graphite seal
XE	Xtreme/Stainless steel seat, graphite seal
XF	Xtreme/Alloy 20 seat, graphite seal
XH	Xtreme/Monel seat, graphite seal

9	Model code
C	Model code

10	Modifier code
—	Standard
QY	Live-loaded packing
MM ³	Composite shaft bearings, Filled PEEK thrust bearings and excluder rings (High Cycle Construction)
	For other, please describe. Factory will supply code.

Hastelloy is a registered trademark of Haynes International, Inc
Monel is a registered trademark of INCO Alloys International, Inc.

- 1 Material meets NACE MR0103 requirements for sour environments. For valves to be in full compliance with NACE MR0103, both the body (sign #6) and trim (sign #7) must meet the NACE MR0103 requirement.
 - 2 Valves with the Disc & Shaft Material Code “00” (sign #7) meet the NACE MR0103 requirement for sour environments if the body code (sign #6) is 71.
 - 3 Modifier code MM requires seat & seal material XZ.
 - 4 Not available with 22 body material.
 - 5 Non-standard seat offering replaced by Xtreme Seat (XZ) offering.
- Consult factory regarding other materials of construction that are not listed.

Standards and specifications

Series 815 & 830 valves covered in this bulletin are available to conform to the following industry standards and specifications.

The company

ISO 9001 – 2015

Pressure Equipment Directive 2014/68/EU

The product - standard

API 607	American Petroleum Institute - Fire Test for Soft Seated Valves (Division of refining)
BS 6755	British Standard Testing of valves Part 2. Specification for fire type-testing requirements
ASME B16.10	American National Standard - Face-to-Face and End-to-End Dimensions of Ferrous Valves 3" – 24" only, 2-1/2" and 5" and not defined in ASME B16.10
ASME B16.5	American National Standard - Steel Pipe Flanges and Flanged Fittings 3" – 24" only
ASME B16.47	American National Standard - Large Diameter Steel Flanges NPS 26 through NPS 60
ASME B16.34	American National Standard - Steel Valves - Flanged and Buttwelded End
ASME B31.1	American National Standard - Power Piping
ASME B31.3	American National Standard - Chemical Plant and Petroleum Refinery Piping
ASME B31.4	American National Standard - Liquid Transportation Systems for Hydrocarbons (Liquid Petroleum Gas), Anhydrous Ammonia, and Alcohols
ASME B31.8	American National Standard - Gas Transmission and Distribution Piping Systems
ANSI/FCI 70-2	American National Standard - For Control Valve Seat Leakage
ISA 75.02	Valve Sizing Coefficient Cv, Piping Geometry Factor Fp and Pressure Drop Limitation XT
MSS SP-25	Manufacturers Standardization Society - Standard Marking System for Valves
MSS-SP-44	Steel Pipe Line Flanges
MSS-SP-55	Manufacturers Standardization Society - Quality Standards for Steel Castings
MSS-SP-61	Pressure Testing of Steel Valves
MSS SP-96	Terminology for Valves and Fittings

Optional

API 598	American Petroleum Institute - Valve Inspection and Testing
API 609	American Petroleum Institute - Butterfly Valves: Double Flanged, Lug- and Wafer-Type 3" – 24" only, 2-1/2" and 5" and not defined in API 609. Requires API 598 testing.
MSS SP-68	Manufacturers Standardization Society - High Pressure Butterfly Valves with Offset Design. Requires API 598 testing.
2014/68/EU	Pressure Equipment Directive - See "How to Order" Section
MSS SP-53	Quality Standard For Steel Castings and Forgings for Valves, Flanges and Fittings and Other Piping Components - Magnetic Particle Examination Method
MSS SP-54	Quality Standard For Steel Castings for Valves, Flanges and Fittings and Other Piping Components - Radiographic Examination Method
MSS SP-93	Quality Standard For Steel Castings and Forgings for Valves, Flanges and Fittings and Other Piping Components - Liquid Penetrant Method
NACE	Standard MR0103 National Association of Corrosion Engineers - Engineers - Materials Resistant to Sulfide Stress Cracking in Corrosive Petroleum Refining Environments

Subject to change without prior notice.

Neles, Neles Easyflow, Jamesbury, Stonel, Valvcon and Flowrox, and certain other trademarks, are either registered trademarks or trademarks of Valmet Oyj or its subsidiaries in the United States and/or in other countries.

For more information www.neles.com/trademarks

Valmet Flow Control Oy

Vanha Porvoontie 229, 01380 Vantaa, Finland.

Tel. +358 10 417 5000.

www.valmet.com/flowcontrol

